

The 2012 International Forum on Design for Manufacture and Assembly, Providence RI

How to Boost Cost Savings: Combining DFMA with the VAVE Approach

Ric Pena & Sundar Kamath, Sanmina Mechanical Systems, San Jose CA

An OEM Designer's Cost Dilemma

Driven by business and time to market needs, Original Equipment Manufacturers (OEMs) must also meet the performance targets of the product they are designing. Starting from the concept phase, OEMs must ensure the product fulfills customer and market needs. Often, the designer places very little, if any, emphasis on the product's material selection, fabrication or ease of assembly. Consequently, the company resolves issues of poor manufacturability only after the product is designed – reducing the total cost savings.

The Solution – Early Integration of Manufacturability and Supply Chain

Our experience has shown that integrating Design for Manufacture and Assembly (DFMA) concepts early into the design cycle, or Early Involvement of DFMA (EI-DFMA) can lead to significantly higher cost savings – between 25% and 40% at the component level. DFM analysis also identifies cost avoidance measures, helping to further reduce expenditure.

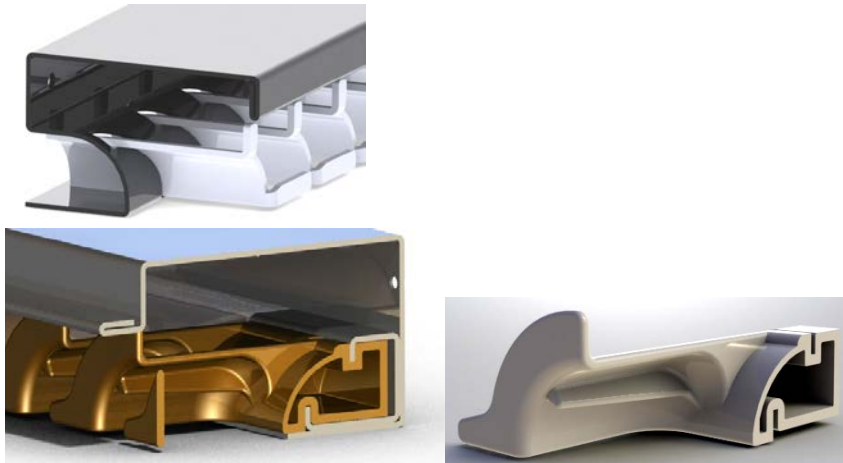

Example 1. Redesign from a welded sheet metal part to a UL-94VO plastic resin molded part, justified thru BDI-DFMA® analysis which showed cost savings of 42% per piece.

To meet time to market requirements, initiate EI-DFMA with your manufacturing partner to incorporate cost savings ideas during the first design iteration. While the preliminary design may be rough and incomplete, it is a good basis to initiate concept reviews to obtain management support for full scale development. Once approved, OEM engineers should ensure the product meets functionality and cost targets in its very first design cycle, without the option of additional design re-spins. The chances of

meeting cost goals early on are much greater if the OEM initiates EI-DFMA with the manufacturing partner. Together, they can define product, material, fabrication, assembly processes and “what-if” scenarios on cost trade-offs versus feature, function, form and appearance. The manufacturer can then provide options for cost reduction and product manufacturability features that optimize design choices.

Making Better Decisions: The VAVE Methodology

What if you can optimize the early phases of a project, so that the product can be manufactured without compromises to its design? Not only would this instill greater confidence in your design engineering team, but you would be able to incorporate manufacturability improvements with minimal delays to schedule.

Value Added Value Engineering (VAVE) is a decision making process that maximizes product features and needs. It considers the cost impact of alternative design ideas, which enhance both manufacturability and value.

To provide effective EI-DFMA services, we incorporate the Boothroyd Dewhurst DFMA® (BDI-DFMA®) program into our comprehensive VAVE process. Sanmina designs and manufactures electronics and electro-mechanical systems, sub-systems and components for OEMs in networking, telecommunications, industrial, semiconductor, capital equipment, medical and related markets. These systems include mechanical components which require fabrication processes such as sheet metal fabrication, complex welding, precision machining, injection molded plastics and aluminum die castings.

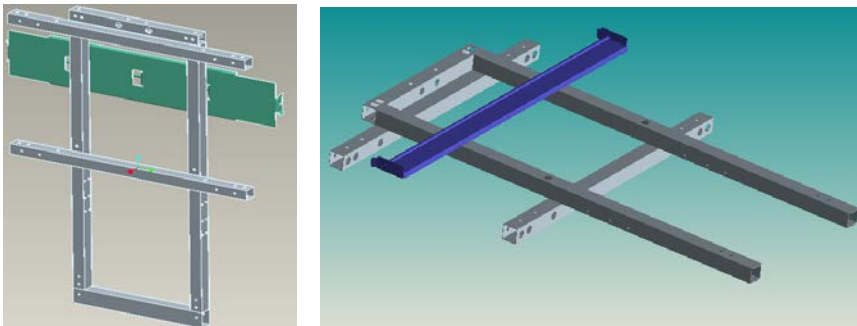

Example 2. Redesigned frame structure from a welded tubing structure to a riveted sheet metal design. BDI DFMA® analysis shows cost savings of 58%, significant enough to justify the change.

Most customers require Build-to-Print (BTP) services, where they have completed the product design and need a contract manufacturing partner like Sanmina to build volume products. Other customers may request either collaborative design support or turnkey design services. BTP customers submit their design package to obtain a manufacturing quote. Our engineering groups use tools including the BDI-DFMA® approach to develop “should costing” data and verify potential cost savings from proposed design, material or fabrication process changes to the existing design. Our costing proposal includes recommendations to reduce component costs based on DFMA and value engineering best practices for machining, sheet metal, plastics, die castings and assembly. Incorporating the BDI-DFMA® analysis into our VAVE approach allows us to make recommendations with greater confidence, helping to optimize the OEM’s future product decisions.

When working with turnkey or collaborative design customers, we introduce the BDI-DFMA®-based VAVE analysis early in the design cycle. Findings are discussed during concept design reviews with manufacturing engineers. Clearly, this is a more effective way of applying EI-DFMA with the BDI-DFMA® tool and leads to higher savings than the BTP application.

Sanmina uses the Design for Concurrent (DFC) costing and Design for Assembly (DFA) to apply material and machinery process selections to both the “What If” scenarios, as well as alternative assembly processes. The BDI software asks material or process questions which the user would normally tend to ignore, refining the product development process. The DFC/DFA software helps engineers manage product complexity by consolidating parts in a seamless manner and analyzing various cost savings scenarios. At the end of the session, we generate reports which give detailed outlines of the product changes for the OEM and the factory.

Our customers are continuously challenging our engineering team to “think out of the box” and generate cost savings without compromising the look or feel of a product. As part of a broader sustaining engineering effort, we also receive many requests to redesign existing products. To meet customer expectations, we must consider multiple factors. For instance, DFMA driven changes need to consider the impact on component functionality. Safety and structural integrity are additional factors influencing cost, and as a result may have a significant impact on final design decisions.

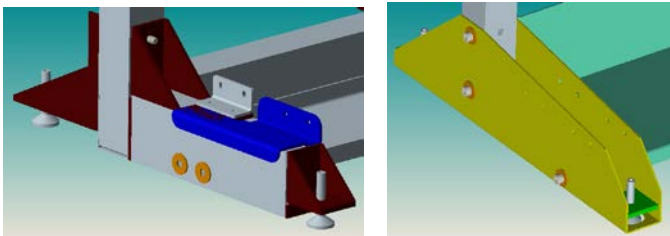

Example 3. Redesign of a frame pedestal foot combining front and back features, which reduced parts from 11 to 5 parts, eliminated other brackets. The hardware reduction went from 5 bolts to 3 bolts. The changes were supported thru BDI-DFMA® analysis which showed projected cost savings of 37%

Building Customer Success

It took up to three years for our EI-DFMA methodology to evolve into the successful tool it is today. Based on our experience, we involve only experienced engineers who are well-trained in the BDI-DFMA® software tool. Successful implementation and major VAVE projects also require a cross-functional team: from design, cost estimation, tooling and supply chain to component and manufacturing engineering. We proactively apply these techniques in the cost proposal phase of BTP projects. We also embed this method into the concept phase of design projects when the customer initially requests design services. This way, we can manage DFMA driven cost savings and changes to the design within time to market constraints. Our team has implemented a structured process and reporting format. Comprehensive design analysis and reports not only add value to the design, but offer a clear understanding of the recommendations during the approval process, so OEMs can make more informed decisions.